



BURTON SPAS

“DOLLAR FOR DOLLAR, THE BEST SPA ON THE PLANET”



“OUR MISSION IS TO DELIVER THE BEST SPA FOR THE DOLLAR THAT YOU CAN BUY, TO LEAVE AS LITTLE A FOOTPRINT AS POSSIBLE BEHIND. ALONG THE WAY WE HAVE FOUND THAT THESE 2 PHILOSOPHIES ACTUALLY GO HAND IN HAND. WHEN WE STOPPED WASTING WE STOPPED SPENDING.”

Every part of our business model
revolves around this belief.



BURTON SPAS

"DOLLAR FOR DOLLAR, THE BEST SPA ON THE PLANET"

ABOUT OUR SPAS

At Burton Spas, we use quality parts and materials that keep products in service and out of landfills. When we have the opportunity to switch to better components and still deliver great value to end consumers we do it. We think of it as short-term pain for long-term gain.

Always use recyclable materials so when the day comes (if it does) that your unit cannot be reasonably repaired that it can be recycled and used again as something else. In fact, there is no material wastage in that all of the material is consumed in making the part. In the event that trimming is required that material is re-used.

We reduce our carbon footprint every way possible. No wasted paper except where required by law.

No wood – nothing to rot. Need we say more?

No special delivery equipment required – this product can be loaded in a truck, taken to location, and literally rolled into place.

Electrical all included – easy to install – easy to move. Burton Spas just plug into a dedicated wall socket. No need to pay expensive electrical contractors. This could easily save you up to \$1000!!!

FEATURES



UNIBODY CONSTRUCTION

Nobody wants to wonder if they have unwanted visitors living inside their spa. Our unique unibody design makes this virtually impossible. Peace of mind is built right in. An amazing amount of portable spas require very expensive repairs resulting from these pesky visitors. Our unique polymer Granitt™ shell surface that is extremely durable and easy to clean. Simply wipe it down as needed. The Granitt™ shell is resistant to exposure to the sun, has a high temperature resistance and is SUPER IMPACT RESISTANT!!!! Virtually impervious to the weather.



IMAGINIT CABINET

Finally we invite you to investigate our exclusive optional exterior digital wrapping process which allows us to create almost any exterior look imaginable. Let our creative staff custom design the perfect look for your spa.



RIGHT SIZE SPA

When many spa owners look back, they find that over 90% of the time there is only one or two people using the spa at a time. Your spa should seat four, but not be so large that it impossible for it to be energy efficient on 110 volts. Larger "party" spas require larger pumps and very expensive 220 volt installations. Buy a spa that is the right size for you, not the whole neighborhood. Make sure the height is at least 32 inches and staying under 300 gallons is a good idea.



HOT TUB GENIE OZONE

Hot Tub Genie Ozone water treatment is standard – many spas have expensive and complicated ozone systems. Our Hot Tub Genie ozone system is proven technology which continues to amaze. There are fancier sounding systems out there, but dollar for dollar the Hot Tub Genie provides the best value. Very effective at helping reduce the amount of time and money you spend maintaining your spa water – and very friendly to the environment.



TOP LOADING FILTERS

These are readily accessible for quick cleaning. Enjoy a safe, healthy spa environment without the hassles. Automatic level sensing filter weirs adjust for changes in water level to provide the best cleaning possible whether the spa is in use or not. Fully programmable filtration cycles help make water maintenance a breeze.



FREEFORM SEATING

Allows you to move freely throughout the spa. Open seating maximizes space and seating capacity. Owners of Burton Spas tell us that they love the freedom and extra space that barrier free seating gives them.



PLUG AND PLAY

All Burton spas use Plug-N-Play technology and come with a GFCI power cord that can be plugged into any standard 110v outlet, allowing you to start enjoying your hot tub right away. Simply fill it up, plug it in and enjoy! Portability and ease of installation are also key features of our products. Installing our spas is as simple as 1-2-3. First, place the spa on a flat, level surface. Second, fill it up with water from a garden hose. Third, plug in and enjoy!

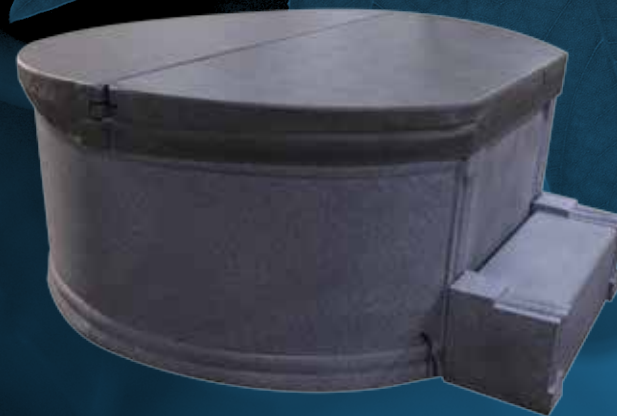

NOT JUST ANOTHER CHEAP COVER

Burton Spas uses marine grade vinyl designed to resist ultraviolet rays and mildew and sewn with polyester thread for longer life. The foam core is made from light, tapered, polystyrene foam reinforced with metal channels for durability. It is then sealed in 4mil plastic to prevent water saturation. All covers come standard with foam hinge bumpers to prevent heat loss, four locking fasteners, and two reinforced handles.



FULLY INSULATED

Don't confuse fully insulated with fully foamed. We have spent years trying to perfect the best insulation system possible. Under license we use patented heat transfer systems to make sure that every bit of energy you put into your hot tub is used to clean, heat, or massage. In many cases we are able to do all three of these things at once for optimum efficiency.

HYDROTHERAPY

FEEL BETTER WITH REGULAR BURTON
HYDROTHERAPY SESSIONS.

HEALING BENEFITS OF HYDROTHERAPY

The healing benefits of hydrotherapy have been known to all of the world's great cultures, with a history that dates back thousands of years.

Ancient Egyptians bathed in heated waters treated with flowers and herbs, while the Greeks believed that water therapy was essential to optimal health. In India, hydrotherapy was an essential ingredient to well-being with treatment.

The Romans were famous for their hot spring baths, and developed architecturally magnificent healing centers built around the use of water for wellness. Much like today's spas, the Roman baths included heated pools used in conjunction with steam treatments. Japan and Germany have historically used natural hot springs for hydrotherapy in an attempt to treat medical conditions, enhance beauty, and promote healthy aging.

In its modern form, hot tub hydrotherapy has been found to be effective in treating muscle pains and stiffness, inflammatory disease, and the symptoms of daily stress. Particularly effective are spa hydrotherapy treatments that combine the components of heated water, water massage, and reduction of pressure on sore joints by decreasing body weight through buoyancy.

Today, Burton Spas continues these centuries-old traditions by enhancing the restorative properties of water. Burton spa hydrotherapy uses massage, heat and buoyancy to accelerate your body's natural healing process, and promote physical and mental well-being.

THREE ELEMENTS OF BURTON SPAS HOT TUBS

Whether you're juggling work and family, recovering from a joint or muscle injury, or simply needing to unwind from the day's stresses, spa hydrotherapy provides both relaxation, healing effects and nourishing rejuvenation.

- 1 HEAT:**
Improves circulation and speeds recovery in damaged tissue.
- 2 BUOYANCY:**
Reduces effects of pressure on joints and spine.
- 3 MASSAGE:**
Relieves muscle tension and alleviates stress.



ARTHRITIS RELIEF

When arthritis strikes, simple activities of daily living, like buttoning a shirt or starting the car, become difficult due to stiff joints and decreased mobility. Even minor arthritis pain can interfere with your daily routine.

Burton Spas' hydrotherapy can help relieve arthritis symptoms:

The heat from the warm water relaxes the entire body as it increases blood flow.

The massaging action of the jets loosens muscle tension and soothes sore joints.

The water's buoyancy makes you feel lighter, with up to 90% of your body weight lifted.

Burton Spas controls let you set the water temperature. You can get a customized massage from adjustable jets, such as the patented jets, which are particularly effective in troublesome areas such as the neck and wrists. The best part is you can take advantage of your Burton hot tub every day, and enjoy effective, hydro therapeutic pain relief.



WARM WATER THERAPY

Since ancient times, warm water has been used to promote general health and well-being. What medical science proves today, the Greeks, Romans, Japanese, and others discovered long ago – warm, soothing water restores our body, mind, and spirit.

But unlike in ancient civilizations, when people had to live near hot springs or build expensive bath houses to enjoy the benefits of warm water therapy, today anyone can access the healing power of water in their own home thanks to affordable Burton Spas.

Burton Spas are ergonomically designed to ensure your body is enveloped in healing, restorative streams of warm water, while you enjoy the luxury of immersion and escape from everyday worries.

The power of heat and soothing warm water, combined with our unique massaging action has been recommended to treat many common conditions, including:

- Stress
- Arthritis
- Sleep disorders
- Diabetes
- Muscle soreness
- Joint pain

Has a medical professional recommended warm water therapy to improve a health condition? Or do you want to include the daily rejuvenating effects of hydrotherapy into your healthy lifestyle? Either way, a Burton Spa is the perfect way to improve your well-being every day.



STRESS RELIEF

Burton Spas hydrotherapy can be an effective way to reduce the effects of stress on a consistent, day-to-day basis. Spa stress relief starts simply: a warm water massage in a Burton hot tub makes you feel good! What better reward after a hard day than sinking into your Burton hot tub and letting the combination of heat, buoyancy, and massage, or hydrotherapy, help you relax? Burton hydrotherapy also has the power to bring about positive physical changes that can alleviate stress.

Effective hydrotherapy increases blood circulation, which can help relieve tension headaches caused by stress.

Massaging jets, can directly soothe tightness in stress-prone areas, like the neck and shoulders.

Warm, massaging water helps stimulate the body's natural production of endorphins, which reduce feelings of pain and anxiety.

Just owning a Burton Spa gives you a reason to take time out of your busy schedule on a regular basis, relieve stress, and reconnect with those close to you. A Burton spa can be a great place to discuss the day's events in a calming environment, free from distractions.



SPA SPECS

VERSA

Dimensions :	84" x 78.625" x 34"
Weight :	400lbs Dry / 2700lbs Wet
Jet Count :	19 Stainless Steel Jets
Ozone :	Hot Tub Genie Standard
Complete Floor :	Standard
Cover :	4.5" x 3.5" Tapered
Control System :	Gecko
Pump :	1.5HP Aquaflo
Stainless Steel Accents :	Standard
Imaginit Cabinet :	Optional

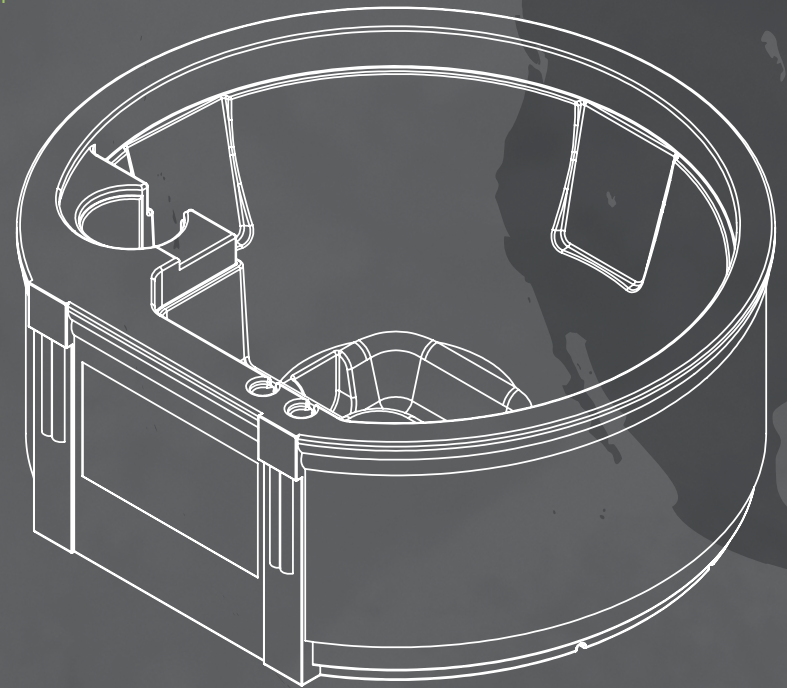

BURTON SPAS

"DOLLAR FOR DOLLAR, THE BEST SPA ON THE PLANET"

BURTONSPAS.COM